

WIFI 2.4GHz

Module Specification

IEEE 802.11b/g/n,1T1R,150Mbps,USB 2.0 Interface

CUSTOMER		CHECKED	APPROVED
	SIGNATURE		
APPROVAL	DATE		
ANRAY		CHECKED	APPROVED
APPROVAL	SIGNATURE	zhangjianfei	
VERSION		DATE	2018.10.21
		2018.10.21	2018.10.21

Anray Communication Technology CO.LTD

北京偶极通信设备有限责任公司



Contents

1.General description.....	.3
2. Features.....	3
3. Application Diagrams.....	4
4. RF specification.....	5~7
5. General specification.....	8
6. Software.....	8
7. Pin Definition.....	8
8. Application circuit diagram.....	9
9. Recommended SMT temperature.....	10
10. Package.....	11

1. General description

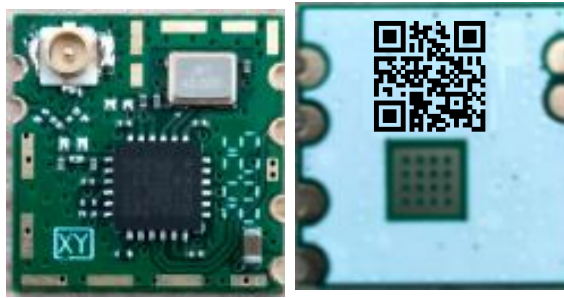

P/N: Anray200830791GE05
(Size:12.67*12.3*2.0mm)

This document is to specify the product requirements for 802.11 b/g/n USB Module. This Card is complied with IEEE 802.11g, IEEE 802.11b, IEEE 802.11n standard from 2.4G-2.5GHz, and it can be used to provide up to 54Mbps for 802.11g, 11Mbps for 802.11b and 150Mbps for 802.11n to connect your wireless LAN.

With seamless roaming, fully interoperability and advanced security with WEP standard, 802.11b/g/n USB Module offers absolute interoperability with different vendors 802.11b, 802.11g, 802.11n Access Points through the wireless LAN.

2. Features

- Compatible with IEEE 802.11b standard to provide wireless 11Mbps data rate.
- Compatible with IEEE 802.11g standard to provide wireless 54Mbps data rate.
- Compatible with IEEE 802.11n standard to provide wireless 150Mbps data rate.
- Operation at 2.4G-2.5GHz frequency band to meet worldwide regulations
- Dynamic data rate scaling at 6,9,12,18,24,36,48,54 for IEEE802.11g
- Dynamic data rate scaling at 1,2,5.5, and 11Mbps for IEEE802.11b
- Maximum reliability, throughput and connectivity with automatic data rate switching
- Support wireless data encryption with 64/128-bit WEP for security
- Support infrastructure networks via Access Point and ad-hoc network via peer-to-peer communication
- Drivers support Windows 2000, XP, Vista
- High speed USB 2.0 interface
- RoHS compliant.

3. Application Diagrams

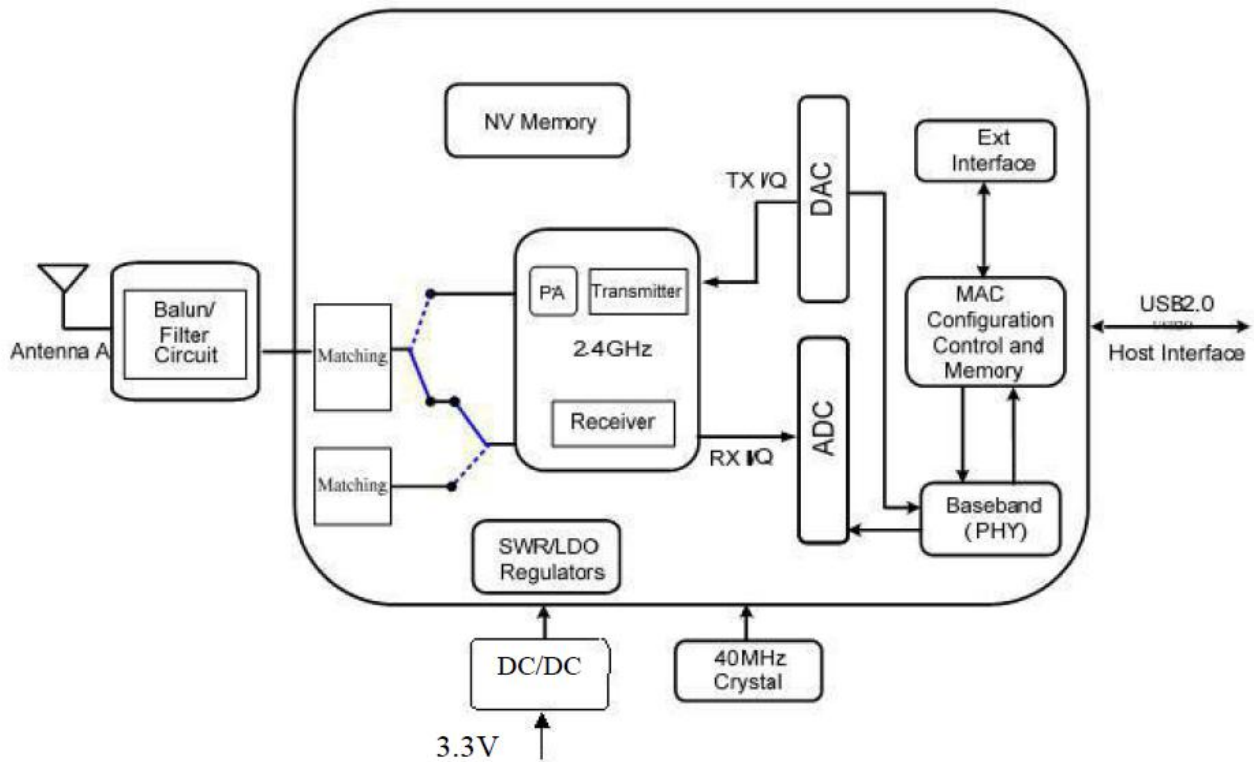

4. RF specification:

4.1 IEEE 802.11b section

Feature	Detailed Description
Standard	<ul style="list-style-type: none">• IEEE 802.11b
Radio and Modulation	<ul style="list-style-type: none">• DQPSK , DBPSK , DSSS , and CCK
Operating Frequency	<ul style="list-style-type: none">• 2400 ~ 2497MHz ISM band
Channel Numbers	<ul style="list-style-type: none">• 11 channels for United States• 13 channels for Europe Countries(Default)• 14 channels for Japan
Data Rate	<ul style="list-style-type: none">• 11, 5.5, 2, and 1Mbps
Media Access Protocol	<ul style="list-style-type: none">• CSMA/CA with ACK
Transmitter Output Power at Antenna	<ul style="list-style-type: none">• Typical RF Output Power at each RF chain,Data Rate and at room Temp. 25degree C• 17±1dBm at 1,2,5.5,11Mbps
Receiver Sensitivity at Antenna Connector	<ul style="list-style-type: none">• Typical Sensitivity at Which Frame(1000-byte PDUs)Error Rate=8%• -81dBm at 1Mbps• -80dBm at 2Mbps• -79dBm at 5.5Mbps• -76dBm for 11Mbps

4.2 IEEE 802.11g section

Feature	Detailed Description
Standard	<ul style="list-style-type: none"> IEEE 802.11g
Radio and Modulation Type	<ul style="list-style-type: none"> QPSK , BPSK , 16QAM ,64QAM with OFDM
Operating Frequency	<ul style="list-style-type: none"> 2400 ~ 2483.5MHz ISM band
Channel Numbers	<ul style="list-style-type: none"> 11 channels for United States 13 channels for Europe Countries(Default) 13 channels for Japan
Data Rate	<ul style="list-style-type: none"> 6,9,12,18,24,36,48,54Mbps
Media Access Protocol	<ul style="list-style-type: none"> CSMA/CA with ACK
Transmitter Output Power at Antenna Connector	<ul style="list-style-type: none"> Typical RF Output Power (tolerance\pm2dB) at each RF chain,Data Rate and at room Temp. 25degree C 16\pm1dBm at 6~18Mbps 15\pm1dBm at 36 and 24Mbps 15\pm1dBm at 54 and 48Mbps
Receiver Sensitivity at Antenna Connector	<ul style="list-style-type: none"> Typical Sensitivity at Which Frame(1000-byte PDUs)Error rate=10% -87dBm at 6Mbps -86dBm at 9Mbps -84dBm at 12Mbps -82dBm for 18Mbps -79dBm at 24Mbps -75dBm at 36Mbps -71dBm at 48Mbps -70dBm for 54Mbps

4.3 IEEE 802.11n section

Feature	Detailed Description																																																	
Standard	<ul style="list-style-type: none"> IEEE 802.11n 																																																	
Radio and Modulation Type	<ul style="list-style-type: none"> BPSK , QPSK , 16QAM ,64QAM with OFDM 																																																	
Operating Frequency	<ul style="list-style-type: none"> 2400 ~ 2483.5MHz ISM band Channel Frequency for HT20: 2412~2472MHZ Channel Frequency for HT40: 2422~2462MHZ 																																																	
Data Rate(Mbps)	<ul style="list-style-type: none"> TX/RX: MCS0 ~MCS7 <table border="1"> <thead> <tr> <th rowspan="2">MCS</th> <th colspan="2">GI=800ns</th> <th colspan="2">GI=400ns</th> </tr> <tr> <th>20MHz</th> <th>40MHz</th> <th>20MHz</th> <th>40MHz</th> </tr> </thead> <tbody> <tr> <td>0</td> <td>6.5</td> <td>13.5</td> <td>7.2</td> <td>15</td> </tr> <tr> <td>1</td> <td>13</td> <td>27</td> <td>14.4</td> <td>30</td> </tr> <tr> <td>2</td> <td>19.5</td> <td>40.5</td> <td>21.7</td> <td>45</td> </tr> <tr> <td>3</td> <td>26</td> <td>54</td> <td>28.9</td> <td>60</td> </tr> <tr> <td>4</td> <td>39</td> <td>81</td> <td>43.3</td> <td>90</td> </tr> <tr> <td>5</td> <td>52</td> <td>108</td> <td>57.8</td> <td>120</td> </tr> <tr> <td>6</td> <td>58.5</td> <td>121.5</td> <td>65.0</td> <td>135</td> </tr> <tr> <td>7</td> <td>65</td> <td>135</td> <td>72.2</td> <td>150</td> </tr> </tbody> </table>	MCS	GI=800ns		GI=400ns		20MHz	40MHz	20MHz	40MHz	0	6.5	13.5	7.2	15	1	13	27	14.4	30	2	19.5	40.5	21.7	45	3	26	54	28.9	60	4	39	81	43.3	90	5	52	108	57.8	120	6	58.5	121.5	65.0	135	7	65	135	72.2	150
	MCS		GI=800ns		GI=400ns																																													
		20MHz	40MHz	20MHz	40MHz																																													
	0	6.5	13.5	7.2	15																																													
	1	13	27	14.4	30																																													
	2	19.5	40.5	21.7	45																																													
	3	26	54	28.9	60																																													
	4	39	81	43.3	90																																													
	5	52	108	57.8	120																																													
6	58.5	121.5	65.0	135																																														
7	65	135	72.2	150																																														
Media Access Protocol	<ul style="list-style-type: none"> CSMA/CA with ACK 																																																	
Transmitter Output Power at Antenna Connector	<ul style="list-style-type: none"> Typical RF Output Power (tolerance\pm2dB) at each RF chain,Data Rate and at room Temp. 25degree C <p>HT 20</p> <ul style="list-style-type: none"> 16\pm1dBm at MCS 0,1 16\pm1dBm at MCS 2,3 15\pm1dBm at MCS 4,5 13\pm1dBm at MCS 6,7 <p>HT 40</p> <ul style="list-style-type: none"> 16\pm1dBm at MCS 0,1 16\pm1dBm at MCS 2,3 15\pm1dBm at MCS 4,5 13\pm1dBm at MCS 6,7 																																																	
Receiver Sensitivity at Antenna Connector	<ul style="list-style-type: none"> Typical Sensitivity at Which Frame(1000-byte PDUs)Error Rate=10% <p>HT20</p> <ul style="list-style-type: none"> -81dBm at MCS0 -81dBm at MCS1 -80dBm at MCS2 -77dBm at MCS3 -74dBm at MCS4 -70dBm at MCS5 -68dBm at MCS6 -66dBm at MCS7 <p>HT40</p> <ul style="list-style-type: none"> -81dBm at MCS0 -79dBm at MCS1 -77dBm at MCS2 -74dBm at MCS3 -71dBm at MCS4 -67dBm at MCS5 -65dBm at MCS6 -63dBm at MCS7 																																																	

5.General specification

Operating temperature:-10°C~+60°C

Storage temperature: -30°C~+85°C

	Feature	Detailed Description
4.2.1	Antenna Type	External antenna
4.2.2	Operating Voltage	3.3.V±0.2V
4.2.3	Current Consumption	350mA at continuous transmit mode 220mA at receive mode w/o receiving packet
4.2.4	USB	High Speed USB2.0 Interface

6. Software

Driver	Windows XP/ WinCE/ Vista,/ Win7, Linux, MAC
Security	64/128-bits WEP, WPA, WPA2

7. Pin Definition(unit:mm)

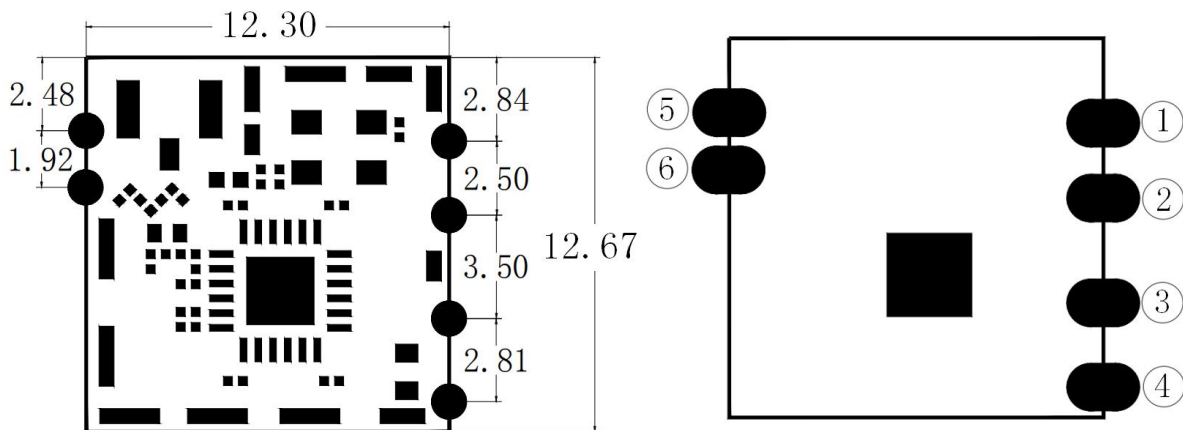

NO.	PIN	I/O Type	Instructions
1	GND	P	Ground
2	UPD	I/O	USB differential signal
3	UDM	I/O	USB differential signal
4	VDD 3.3V	P	3.3V Power
5	GND	P	Ground
6	ANT	RF	RF Reserved feeding

8. Application circuit diagram

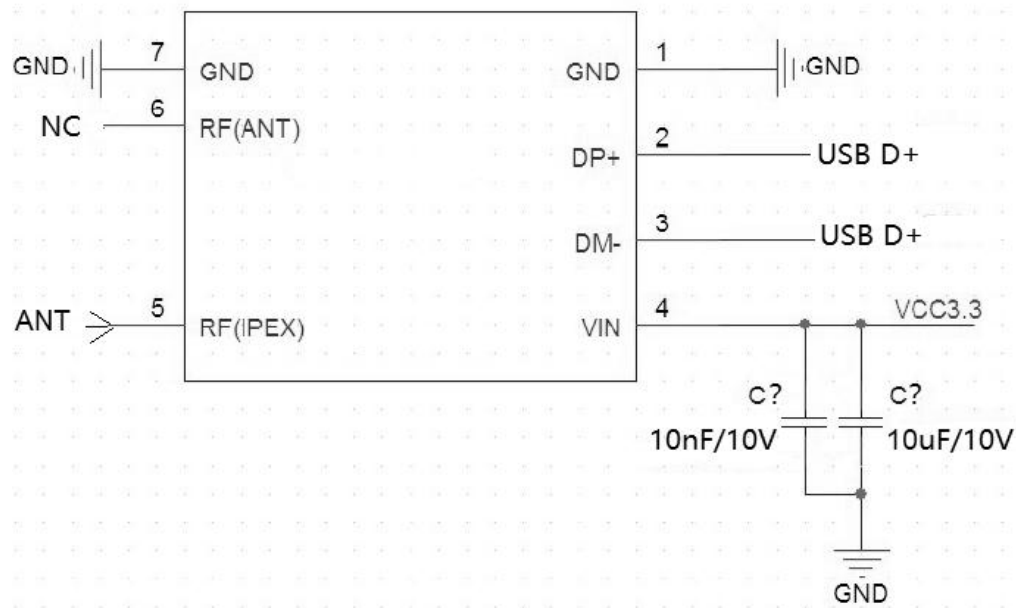

Note: IPEX connector is option.

9.Recommended SMT temperature

Referred to IPC/JEDEC standard.

Peak Temperature : <math><250^{\circ}\text{C}</math>

Number of Times : ≤ 2 times

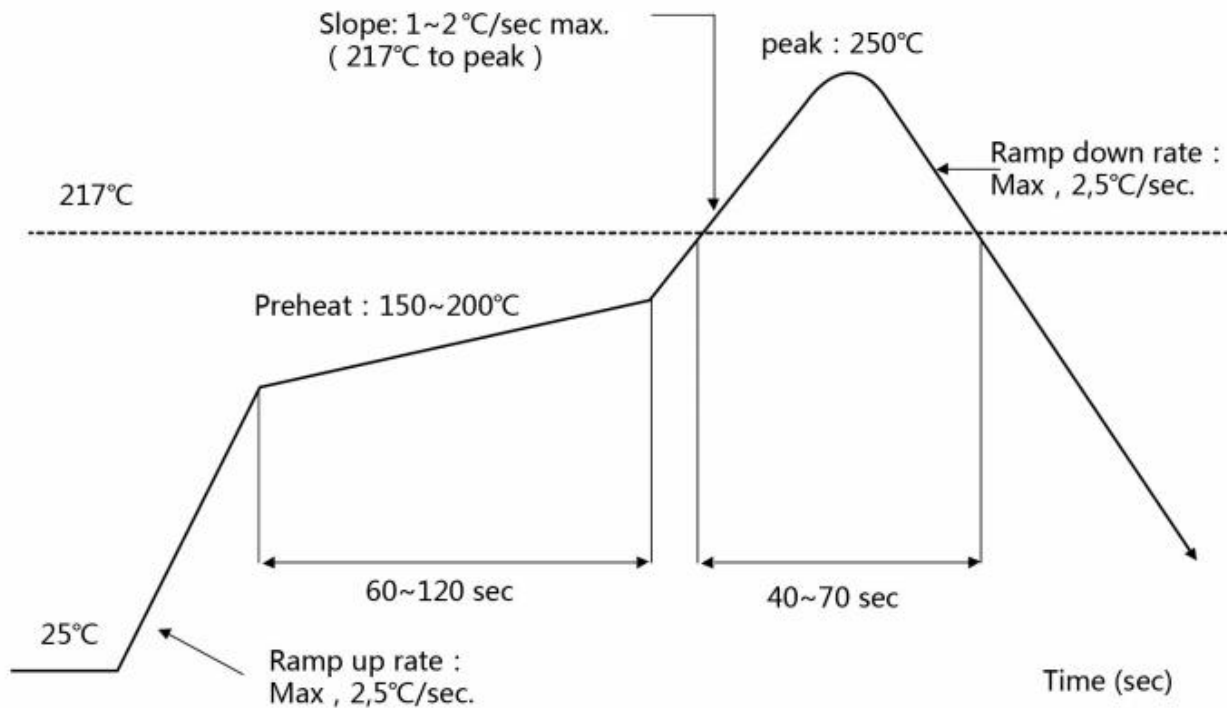

10.Package

Using self-adhesive tape, A roll of 2000pcs.

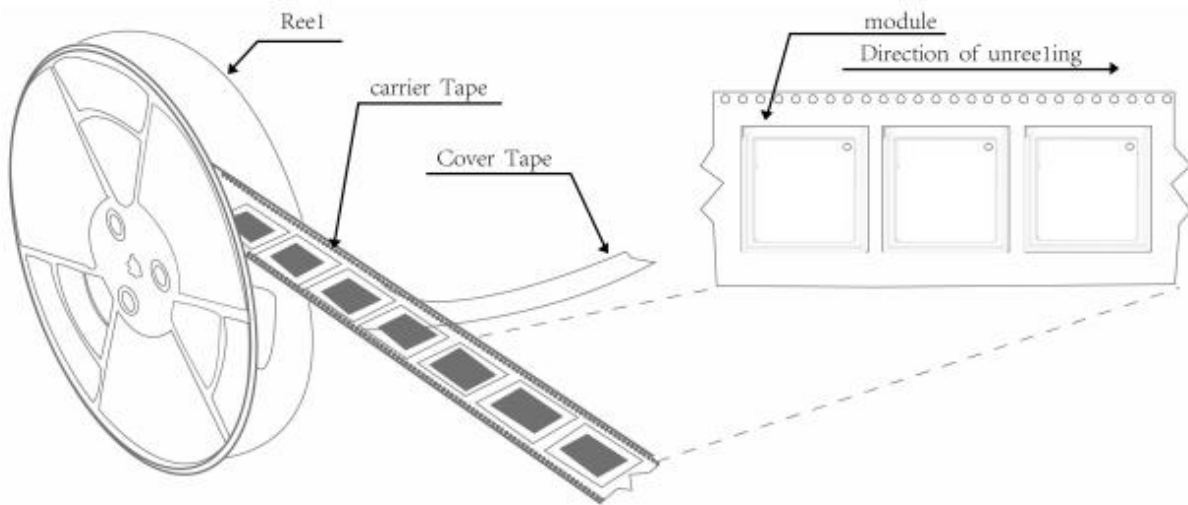

BOX